

HIS MAJESTY'S THEATRE

Technical Information

1/4/2013

Rosemount Viaduct,
ABERDEEN,
AB25 1GL.
Tel: 0845 2708200
Fax: 01224 337690
Company Office Tel: 01224 337694
Stage Door Tel: 01224 337673

A centrally located, Edwardian theatre designed by Frank Matcham, HMT opened in 1906. The theatre is operated by Aberdeen Performing Arts, a charitable company.

Ground plans can be found [Here](#).

Get In

Arched door to lift from outside.

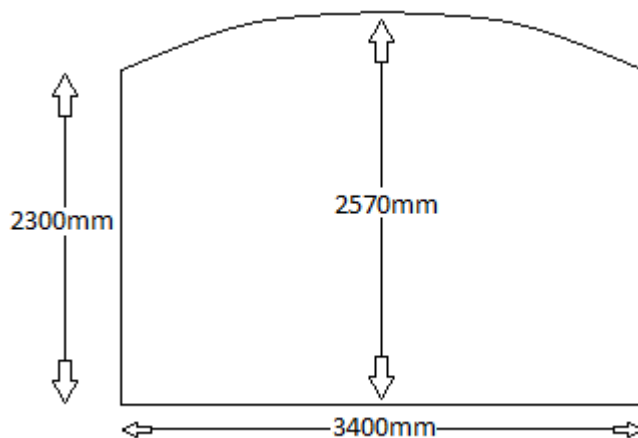

Lift to stage:

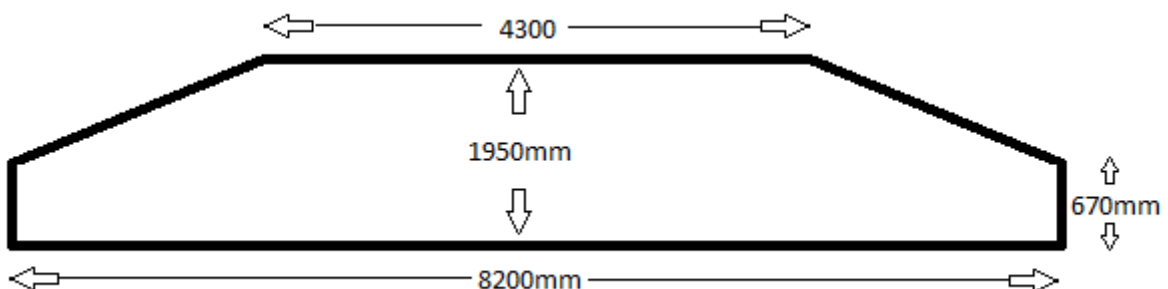

Stage

Proscenium width	9.160m	30'0"
Proscenium height to pelmet	7.086m	23'3"
Max. stage width	20.150m	66'0"
Max. stage depth (to paint frame)	12.2m	40'0"
Depth (iron to last flying bar)	10.74m	35'3"
Depth (iron to stage front)	0.90m	3'0"
Depth (last flying bar to back wall)	5.79m	19'0"
Width (between fly floors)	15.00m/12.25m	49'5"/40'3"
Stage rake	1 in 28	approx.

- The stage floor is covered with black linoleum
60 x Stage weights c/w 20 x Braces
10 x Hard Masking flats of various size

Clearances

Stage floor (downstage) to U.S. grid	15.4m	50'6"
Stage floor (upstage) to U.S. grid	15.04m	49'4"
Stage floor (downstage) to U.S. P.S. Fly floor	6.95m	22'9"
Stage floor (upstage) to U.S. P.S. Fly floor	6.56m	21'6"
Stage floor (downstage) to U.S. O.P. Fly floor	7.40m	24'3"
Stage floor (upstage) to U.S. O.P. Fly floor	7.01m	23'0"

Flying

52 x Counterweighted fly bars (diameter 48mm), spaced at 20cm (8")

Sets 1-39 are single purchase - max. load 400kg (880lb)

Sets 40-52 are double purchase - max. load 300kg (660lb)

Motor assist (chain hoists) is possible on any 3 (of 52) bars increasing capacity to 600kg (1320lb)

SR & SL each have two 500kg (1102lb) upstage/downstage winch bars specifically for Lx side frames and masking drapes.

House Tabs are manually operated from the Fly floor, the Safety Curtain from prompt side.

There is a 3 line 1000kg (2200lb) capacity advanced bar winch down stage of the Proscenium from which a 9.6m (32') truss can be flown.

There are also two 500kg (1100lb) motors above the Proscenium booms to assist with rigging on the pros boom.

Drapes

6 x	Borders	Black serge 39' x 8'
6 pair	Legs	Black serge 24'6" x 8'
1 x	Full Blacks	Plain serge 24'6"
2 x	Full Blacks	Pleated black velour 39' x 24'6"
1 x	Split Blacks	Black serge 39' x 24'6"
5 x	Borders	Dark blue velour 39' x 6'
5 pair	Legs	Dark blue velour 24'6" x 6'
1 x	Full Tabs	Dark blue velour 39' x 24'6"
1 x	Cyclorama	Rosco Isora 'Opera'
1 x	Gauze	White sharks tooth
1 x	Gauze	Black sharks tooth

Touring Sound And Lx Positions.

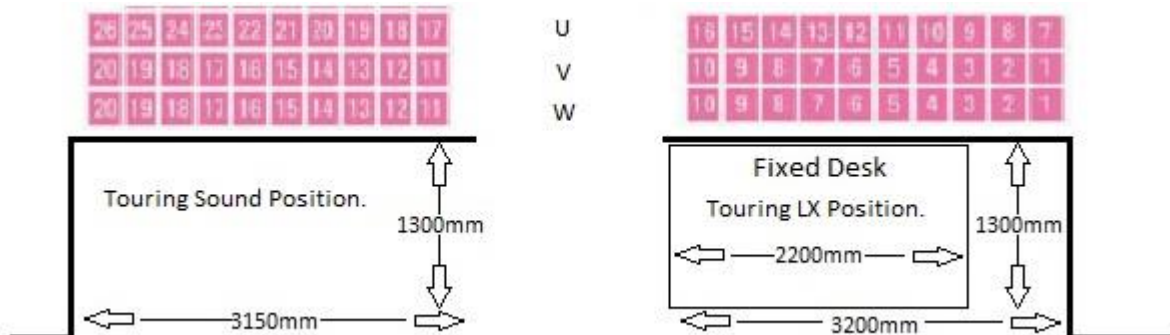

Lighting

1 x Strand 520i, 500 Channel/Attribute Console
1 x Strand 530i, 550 Channel/Attribute Console (normally used as tracking backup)
1 x ETC Sensor Plus Dimmer System (214 x 2.5kW, 26 x 5kW & 24 Non-Dim)

N.B. In-house lighting is controlled from Upper Circle, but visiting company's lighting control can be positioned at rear of Stalls

Fresnels:

24 x Cantata 1,200W
3 x Cadenza 2,000W
7 x Alto 2,500W

Profiles:

2 x ETC Source 4 Zoom 15⁰-30⁰ 750W
12 x ETC Source 4 26⁰ 750W
12 x ETC Source 4 36⁰ 750W
4 x ETC Source 4 50⁰ 750W
10 x ETC Source 4 Juniors 25⁰-50⁰ 575W
2 x Prelude 28/40
16 x ETC Source 4 zoom (FOH fixed rig)
12 x Cadenza 9/15 (FOH fixed rig)

Additional Source 4 lenses of varying size are also available

5 x 19⁰
1 x 26⁰
4x 36⁰
2x 50⁰

Other:

54 x Par 64 (CP62) 1,000W
6 x Pallas 4 groundrow
15 x Iris 1 flood units 1,000W
12 x Par 16 'Birdies'
2 x Robert Juliat Korrigan Plus Follow Spots 1.2kW HMI

Lighting equipment available at additional cost

4 x Varilite VL2500 Spot
4 x Varilite VL2500 Wash
10 x Martin 918
10 x Martin Mac 600 NTE
20 x Rainbow 8" Pro Scrollers
1 x Unique 2 Hazer
1 x ZR20 Smoke Machine
1 x Minimist Smoke Machine
6/24way lematre ProStage II
Various other pyrotechnic equipment.

Power

3 phase, 300A Camlocs (on fly floor SL)
3 phase, 300A Powerlock, Tails or Lugs (sub-stage DSL)
3 phase, 200A Tails or Lugs (sub-stage DSL)
3 phase, 63A CEE (DSL)
Single phase 63A CEE (DSL)
3 x Single phase, 32A CEE (sub-stage DSL)

Sound

1 x Yamaha M7CL 48 channel mixing desk
2 x D&B B2, Sub-base units (at Stalls level)
2 x D&B QSub, (in upper circle)
6 x D&B Q7, (on Prosc. Booms – 1 pair for each level from Dress circle up)
6 x D&B Q1, (3 per side in the stalls)
6 x D&B E6, (used as front fill speakers)
6 x D&B E5, (used as delay speakers in rear stalls)
4 x D&B E5, (Used as delays in the upper circle)

2 x D&B MAX 12 wedge/sidefill monitors
2 x D&B E6 monitors.
2 x D&B E3 monitors.
1 x Yamaha MS101 III Monitor

1 x Yamaha DME 64N digital audio processors

XLR Tie-lines to rear stalls:

Pit SL: 10 Sends, 2 Returns
Pit SR: 10 Sends, 2 Returns
USR: 20 Sends, 4 Returns
USL: 20 Sends, 4 Returns
DSR: 20 Sends, 4 Returns
DSL: 20 Sends, 4 Returns

Speakon Tie-lines:

5 in Prompt corner.
1 X DSL, DSR, USL ,USR ,Flys DSL, Flys DSR, Flys USL, Flys USR.
2 X Upper Circle (For Surround)
2 X Back Stalls (For Surround)

Microphones

2 x Sennheiser ME80
2 x Sennheiser ME66
2 x Sennheiser ME40
2 x Sennheiser K6
7 x Shure SM58
1 x AKG D224
3 x AKG D1200E
2 x AKG D112
1 x AKG D3900
1 x AKG SE300
1 x AKG C460B
1 x EV RE20
2 x Crown PCC160
2 x Crown PCC200
4 x D I Boxes (active)
1 x Beyer Dynamic M201N
1 x Beyer Dynamic MC740N

Sennheiser Drum Kit Microphone Kit:

1 x E602 II
4 x E604
2 x E614

Sound equipment available at additional cost

32 way of Sennheiser radio mics:

28 x sk500 G3 belt packs
8 x SKM Hand Helds.
32 x EW500 Receivers

Microphone Stands

10 x Tall
8 x Short

Music stands

20 x RAT Opera Stands (illuminated)

Communications

Prompt Desk DSL

- 1 x Video Monitor, Stage picture in Colour
- Cue Light control
- Dual channel Ring Intercom
- Backstage and FOH Paging
- Bar Bells

8 x Cue Lights

10 x dual channel intercom belt packs and headsets

4 x single channel radio belt packs and headsets

Video patch on BNC at DSR, DSL, USR, USL, Circle Front, Back Stalls

Communications

Prompt Desk DSL

- 2 x Video Monitors, Stage picture in Colour
- Cue Light control
- Dual channel Ring Intercom
- Backstage and FOH Paging
- Bar Bells

8 x Cue Lights

10 x dual channel intercom belt packs and headsets

4 x single channel radio belt packs and headsets

Video patch on BNC at DSR, DSL, USR, USL, Circle Front, Back Stalls

Orchestra Pit

Small

39' x 6'4"

No seats removed.

Medium

39' x 13'2"

2 rows of seats removed.

Large

39' x 18'

4 rows of seat removed.

5'9"

Height from pit floor to stage.

Seats:

30 x Cushioned

Pianos

1 x Wendl & Lung Full Upright

Dressing Rooms

<u>Level</u>	<u>Room No.</u>	<u>Capacity</u>	<u>Facilities</u>
<u>Ground</u> (Stage door)	<u>1</u>	6	Shower & toilet
	<u>2</u>	5	Shower & toilet
	<u>3</u>	3	Shower & toilet
	<u>4</u>	1	Sink
	<u>5</u>	2	Sink
<u>First</u> (Wardrobe & Pit level)		M & F toilets	
	<u>6</u>	5	Shower
	<u>7</u>	6	Shower
		M & F toilets	
	<u>Band rooms</u>	1 x 20	
		1 x 10	M & F toilets
	<u>Company Office</u>	Comp. Office	Telephone – 2 lines
<u>Second</u> (stage level)	<u>8</u>	3	Sink
	<u>9</u>	3	Shower & toilet
	<u>10</u>	3	Shower & toilet
<u>Third</u>	<u>11</u>	3	Shower
		M & F toilets	
	<u>12</u>	6	Shower
<u>Fourth</u>	<u>14</u>	4	Shower
		M & F toilets	
	<u>15</u>	3	Shower
	<u>16</u>	7	Shower
	<u>17</u>	4	Shower

There is also a Green Room (next to Stage Door) with a communal fridge and some catering facilities.

Wardrobe

- 1 x Miele commercial washing machine. 5kg capacity (token operated)
- 1 x Miele commercial tumble dryer. 6kg capacity
- 2 x Hot/cold/drainage hook-ups for touring washing machines
- 1 x Large double sink and drainer
- 1 x ironing board
- 1 x steam iron
- 1 x sewing machine

Accessibility

There is a lift to dressing rooms 1-10 and the stage for wheelchair users

Show relay audio is available in the auditorium via a dual channel infra-red radiator/headset system which can also be used for audio description