

Rosemount Viaduct,  
Aberdeen,  
AB25 1GL.  
Tel: 0845 2708200  
Fax: 01224 337690  
Company Office Tel: 01224 337694  
Stage Door Tel: 01224 337673

A centrally located, Edwardian theatre designed by Frank Matcham, HMT opened in 1906. The theatre is operated by Aberdeen Performing Arts, a charitable company.

Ground plans can be found [Here](#).

### Get In

Arched door to lift from outside.

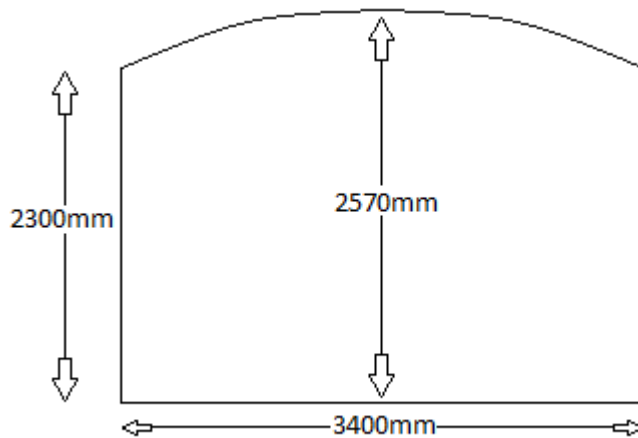

Lift to stage:

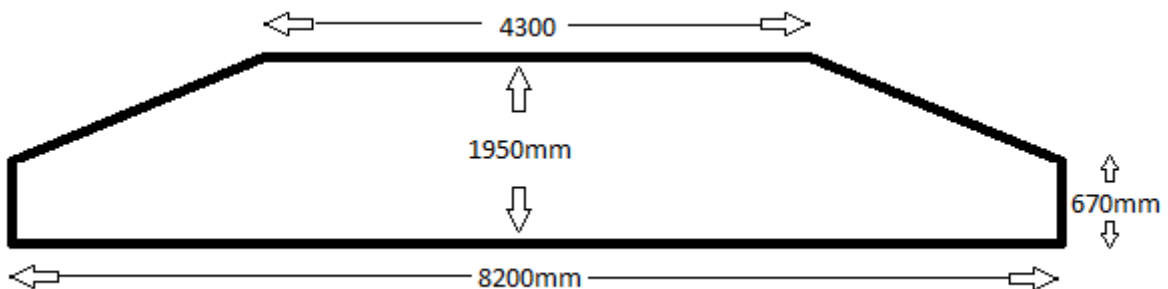

### Stage

Proscenium width	9.160m	30'0"
Proscenium height to pelmet	7.086m	23'3"
Max. stage width	20.150m	66'0"
Max. stage depth (to paint frame)	12.2m	40'0"
Depth (iron to last flying bar)	10.74m	35'3"
Depth (iron to stage front)	0.90m	3'0"
Depth (last flying bar to back wall)	5.79m	19'0"
Width (between fly floors)	15.00m/12.25m	49'5"/40'3"
Stage rake	1 in 28	approx.

- The stage floor is covered with black linoleum  
60 x Stage weights c/w 20 x Braces  
10 x Hard Masking flats of various size

## Clearances

Stage floor (downstage) to U.S. grid	15.4m	50'6"
Stage floor (upstage) to U.S. grid	15.04m	49'4"
Stage floor (downstage) to U.S. P.S. Fly floor	6.95m	22'9"
Stage floor (upstage) to U.S. P.S. Fly floor	6.56m	21'6"
Stage floor (downstage) to U.S. O.P. Fly floor	7.40m	24'3"
Stage floor (upstage) to U.S. O.P. Fly floor	7.01m	23'0"

## Flying

52 x Counterweighted fly bars (diameter 48mm), spaced at 20cm (8")

Sets 1-39 are single purchase - max. load 400kg (880lb)

Sets 40-52 are double purchase - max. load 300kg (660lb)

Motor assist (chain hoists) is possible on any 3 (of 52) bars increasing capacity to 600kg (1320lb)

SR & SL each have two 500kg (1102lb) upstage/downstage winch bars specifically for Lx side frames and masking drapes.

House Tabs are manually operated from the Fly floor, the Safety Curtain from prompt side.

There is a 3 line 1000kg (2200lb) capacity advanced bar winch down stage of the Proscenium from which a 9.6m (32') truss can be flown.

There are also two 500kg (1100lb) motors above the Proscenium booms to assist with rigging on the pros boom.

## Drapes

6 x	Borders	Black serge 39' x 8'
6 pair	Legs	Black serge 24'6" x 8'
1 x	Full Blacks	Plain serge 24'6"
2 x	Full Blacks	Pleated black velour 39' x 24'6"
1 x	Split Blacks	Black serge 39' x 24'6"
5 x	Borders	Dark blue velour 39' x 6'
5 pair	Legs	Dark blue velour 24'6" x 6'
1 x	Full Tabs	Dark blue velour 39' x 24'6"
1 x	Cyclorama	Rosco Isora 'Opera'
1 x	Gauze	White sharks tooth
1 x	Gauze	Black sharks tooth

Decking available at extra cost:

12 x 8ft x 4ft

2 x 4ft x 4ft

2 x 6ft x 5ft

## Touring Sound And Lx Positions.

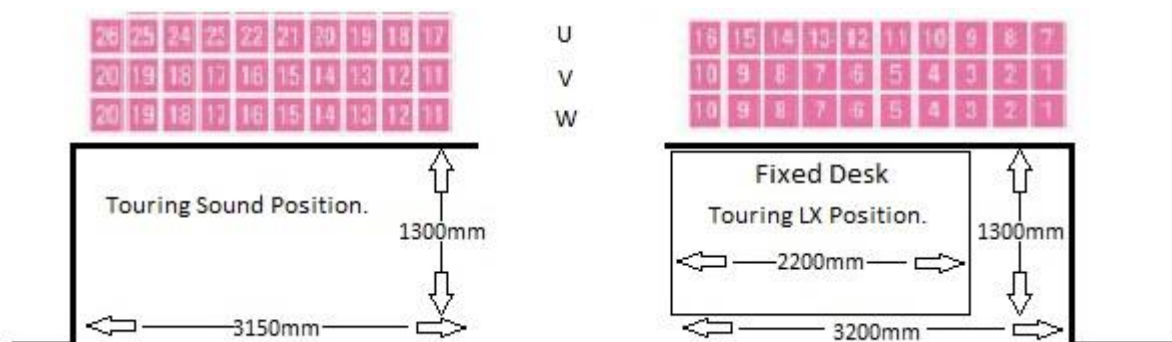

## Lighting

- 1 x ETC GIO console 4000 channel
- 1 x ETC ion console (normally used as tracking backup) 4000 channel
- 1 x ETC Sensor Plus Dimmer System (214 x 2.5kW, 26 x 5kW & 24 Non-Dim)

N.B. In-house lighting is controlled from Upper Circle, but visiting company's lighting control can be positioned at rear of Stalls

### Fresnels:

- 24 x Cantata 1,200W
- 3 x Cadenza 2,000W
- 7 x Alto 2,000W

### Profiles:

- 2 x ETC Source 4 Zoom 15<sup>0</sup>-30<sup>0</sup> 750W
- 12 x ETC Source 4 26<sup>0</sup> 750W
- 12 x ETC Source 4 36<sup>0</sup> 750W
- 4 x ETC Source 4 50<sup>0</sup> 750W
- 10 x ETC Source 4 Juniors 25<sup>0</sup>-50<sup>0</sup> 575W
- 16 x ETC Source 4 zoom (FOH fixed rig)
- 12 x Cadenza 9/15 (FOH fixed rig)

Additional Source 4 lenses of varying size are also available

- 5 x 19<sup>0</sup>
- 1 x 26<sup>0</sup>
- 4x 36<sup>0</sup>
- 2x 50<sup>0</sup>

### Other:

- 50 x Par 64 (CP62) 1,000W
- 8 x Pallas 4 Groundrow
- 15 x Iris 1 flood units 1,000W
- 8 x Par 16 'Birdies'
- 2 x Robert Juliat Korrigan Plus Follow Spots 1.2kW HMI

### Lighting equipment available at additional cost

- 4 x Stark400 LED Wash
- 3 x Varilite VL2500 Spot
- 4 x Varilite VL2500 Wash
- 6 x Martin 918
- 8 x Martin Mac 600 E NT
- 18 x Rainbow 8" Pro Scrollers
- 2 x Unique 2 Hazer
- 6/24way lematre ProStagge II
- Various other pyrotechnic equipment.

## Power

- 3 phase, 400A Powerlock (on fly floor SL)
- 3 phase, 300A Powerlock (sub-stage DSL)
- 3 phase, 160A Powerlock (sub-stage DSL)
- 3 phase, 63A CEE (DSL)
- Single phase 63A CEE (DSL)
- 3 x Single phase, 32A CEE (sub-stage DSL)

## **Sound**

1 x Yamaha M7CL 48 channel mixing desk  
2 x D&B B2, Sub-base units (at Stalls level)  
2 x D&B QSub, (in upper circle)  
6 x D&B Q7, (on Prosc. Booms – 1 pair for each level from Dress circle up)  
6 x D&B Q1, (3 per side in the stalls)  
6 x D&B E6, (used as front fill speakers)  
6 x D&B E5, (used as delay speakers in rear stalls)  
4 x D&B E5, (Used as delays in the upper circle)

2 x D&B MAX 12 wedge/sidefill monitors  
2 x D&B E6 monitors.  
2 x D&B E3 monitors.  
1 x Yamaha MS101 III Monitor

1 x Yamaha DME 64N digital audio processors

### **XLR Tie-lines to rear stalls:**

Pit SL: 10 Sends, 2 Returns  
Pit SR: 10 Sends, 2 Returns  
USR: 20 Sends, 4 Returns  
USL: 20 Sends, 4 Returns  
DSR: 20 Sends, 4 Returns  
DSL: 20 Sends, 4 Returns

### **Speakon Tie-lines:**

5 in Prompt corner.  
1 X DSL, DSR, USL ,USR ,Flys DSL, Flys DSR, Flys USL, Flys USR.  
2 X Upper Circle (For Surround)  
2 X Back Stalls (For Surround)

### **Microphones**

2 x Sennheiser ME80  
2 x Sennheiser ME66  
2 x Sennheiser ME40  
2 x E614  
3 x Shure SM57  
7 x Shure SM58  
1 x AKG D224  
2 x AKG D112  
1 x AKG SE300  
1 x EV RE20  
2 x Crown PCC160  
2 x Crown PCC200  
4 x D I Boxes (active)  
1 x Beyer Dynamic M201N

### **Sennheiser Drum Kit Microphone Kit:**

1 x E602 II  
4 x E604  
2 x E614

### **Microphone Stands**

16 x Tall  
8 x Short

## **Sound equipment available at additional cost:**

### 32 way of Sennheiser radio mics:

28 x sk500 G3 belt packs  
8 x SKM Hand Helds.  
32 x EW500 Receivers

### **Music stands**

At extra cost:

26 x RAT Opera Stands (illuminated)

### **Communications**

Prompt Desk DSL

- 1 x Video Monitor, Stage picture in Colour
- Cue Light control
- Dual channel Ring Intercom
- Backstage and FOH Paging
- Bar Bells

6 x Cue Lights

10 x dual channel intercom belt packs and headsets

4 x single channel radio belt packs and headsets

Video patch on BNC at DSR, DSL, USR, USL, Circle Front, Back Stalls

### **Communications**

Prompt Desk DSL

- 2 x Video Monitors, Stage picture in Colour
- Cue Light control
- Dual channel Ring Intercom
- Backstage and FOH Paging
- Bar Bells

6 x Cue Lights

10 x dual channel intercom belt packs and headsets

4 x single channel radio belt packs and headsets

Video patch on BNC at DSR, DSL, USR, USL, Circle Front, Back Stalls

### **Orchestra Pit**

<u>Small</u>	39' x 6'4"	No seats removed.
<u>Medium</u>	39' x 13'2"	2 rows of seats removed.
<u>Large</u>	39' x 18'	4 rows of seat removed.
	5'9"	Height from pit floor to stage.
	<u>Seats:</u>	30 x Cushioned

### **Pianos**

1 x Wendl & Lung Full Upright

## **Dressing Rooms**

<u>Level</u>	<u>Room No.</u>	<u>Capacity</u>	<u>Facilities</u>
<u>Ground</u> (Stage door)	<u>1</u>	6	Shower & toilet
	<u>2</u>	5	Shower & toilet
	<u>3</u>	3	Shower & toilet
	<u>4</u>	1	Sink
	<u>5</u>	2	Sink
<u>First</u> (Wardrobe & Pit level)		M & F toilets	
	<u>6</u>	5	Shower
	<u>7</u>	6	Shower
		M & F toilets	
	<u>Band rooms</u>	1 x 20	
		1 x 10	M & F toilets
	<u>Company Office</u>	Comp. Office	Telephone – 2 lines
<u>Second</u> (stage level)	<u>8</u>	3	Sink
	<u>9</u>	3	Shower & toilet
	<u>10</u>	3	Shower & toilet
<u>Third</u>	<u>11</u>	3	Shower
		M & F toilets	
	<u>12</u>	6	Shower
<u>Fourth</u>	<u>14</u>	4	Shower
		M & F toilets	
	<u>15</u>	3	Shower
	<u>16</u>	7	Shower
	<u>17</u>	4	Shower

There is also a Green Room (next to Stage Door) with a communal fridge and some catering facilities.

### **Wardrobe**

- 1 x Miele commercial washing machine. 5kg capacity (token operated)
- 1 x Miele commercial tumble dryer. 6kg capacity
- 2 x Hot/cold/drainage hook-ups for touring washing machines
- 1 x Large double sink and drainer
- 1 x ironing board
- 1 x steam iron
- 1 x sewing machine

### **Accessibility**

There is a lift to dressing rooms 1-10 and the stage for wheelchair users

Show relay audio is available in the auditorium via a dual channel infra-red radiator/headset system which can also be used for audio description